

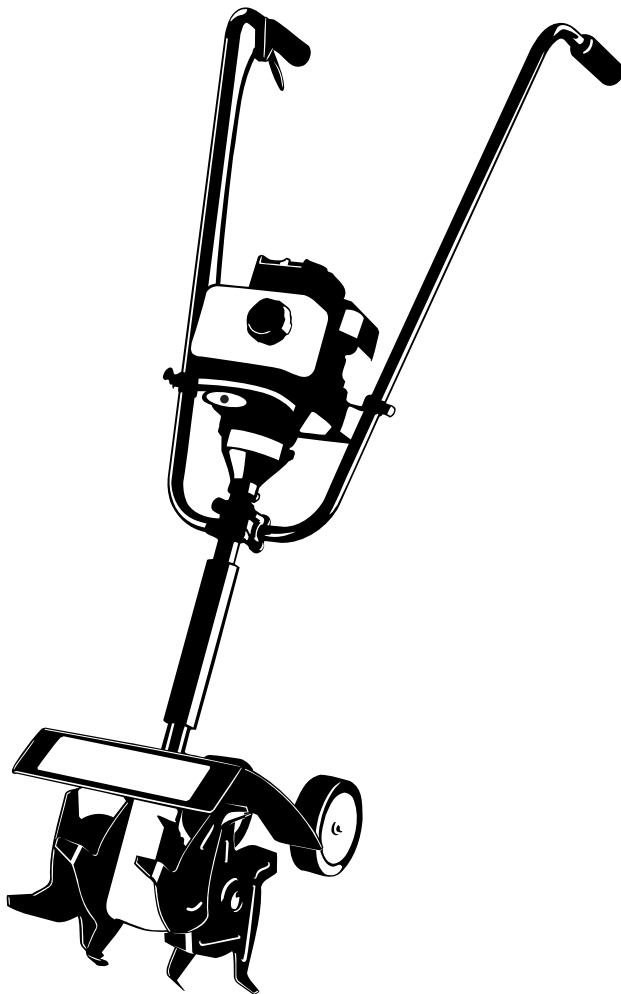

Operator's Manual



**Front Tine
Cultivator
Model
21A-120R000**



IMPORTANT: Read safety rules and instructions carefully before operating equipment.

Warning: This unit is equipped with an internal combustion engine and should not be used on or near any unimproved forest-covered, brush-covered or grass-covered land unless the engine's exhaust system is equipped with a spark arrester meeting applicable local or state laws (if any). If a spark arrester is used, it should be maintained in effective working order by the operator. In the State of California the above is required by law (Section 4442 of the California Public Resources Code). Other states may have similar laws. Federal laws apply on federal lands. A spark arrester for the muffler is available through your nearest engine authorized service dealer or contact the service department, 550 N. 54th Street, Chandler, Arizona 85226-2434.

MTD SOUTHWEST INC 550 N. 54TH STREET, CHANDLER, ARIZONA 85226-2434

PRINTED IN U.S.A.
PART NO. 10120 rev. A

FORM NO. 770-10456
(11/00)

TABLE OF CONTENTS

Content	Page
Important Safe Operation Practices	3, 4
Assembling Your Cultivator	5
Know Your Cultivator	8
Operating Your Cultivator.....	9
Making Adjustments	12
Maintaining Your Cultivator	13
Off-Season Storage	15
Troubleshooting.....	15
Parts List	16

FINDING MODEL NUMBER

This Operator's Manual is an important part of your new cultivator. It will help you assemble, prepare and maintain the unit for best performance. Please read and understand what it says.



Before you start assembling your new equipment, please locate the model plate on the unit and copy the information from it to the space provided below. The information on the model plate is very important if you need help from our Customer Support Department or an authorized dealer.

- You can locate the model number by standing in the operating position behind the unit and looking on the left side of the engine next to the On/Off Stop Control Switch. A sample model plate is explained below. For future reference, please copy the model number and the serial number of the equipment in the space below.

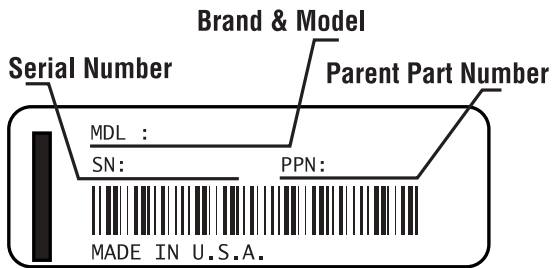

Copy the model number here: _____

Copy the serial number here: _____

Copy the parent part number here: _____

CALLING CUSTOMER SUPPORT

If you have difficulty assembling this product or have any questions regarding the controls, operation or maintenance of this unit, please call the Customer Support Department.



Call 1- (800)-345-8746, or in Canada 1- (800)-668-1238, to reach a Customer Support representative. Please have your unit's model number and serial number ready when you call. See previous section to locate this information. You will be asked to enter the serial number in order to process your call.

SECTION 1: IMPORTANT SAFE OPERATION PRACTICES



This Symbol Points Out Important Safety Information Which, If Not Followed, Could Endanger The Personal Safety And/or Property Of Yourself And Others. Read And Follow All Instructions In This Manual Before Attempting To Operate Your Cultivator. Failure To Comply With These Instructions May Result In Personal Injury. When You See This Symbol–Heed Its Warning.



DANGER: Your cultivator was built to be operated according to the rules for safe operation in this manual. As with any type of power equipment, carelessness or error on the part of the operator can result in serious personal injury. This cultivator is capable of amputating hands and feet. Failure to observe the following instructions could result in serious injury or death.



WARNING: Engine Exhaust, some of its constituents, and certain vehicle components contain or emit chemicals known to State of California to cause cancer and birth defects or other reproductive harm.

GENERAL OPERATION

- Read the instructions carefully. Be familiar with the controls and proper use of the unit.
- Do not operate this unit when tired, ill, or under the influence of alcohol, drugs, or medication.
- Children and teens under the age of 15 must not use the unit, except for teens guided by an adult.
- All guards and safety attachments must be installed properly before operating the unit.
- Inspect the unit before use. Replace damaged parts. Check for fuel leaks. Make sure all fasteners are in place and secure. Replace parts that are cracked, chipped, or damaged in any way. Do not operate the unit with loose or damaged parts.
- Carefully inspect the area before starting the unit. Remove all debris and hard or sharp objects such as glass, wire, etc.
- Clear the area of children, bystanders, and pets. At a minimum, keep all children, bystanders and pets outside a 50 feet (15 m) radius; there still may be a risk to bystanders from thrown objects. Bystanders should wear eye protection. If you are approached, stop the unit immediately.
- Squeeze the throttle control and check that it returns automatically to the idle position. Make all adjustments or repairs before using unit.
- Never start or run the unit inside a closed room or building. Breathing exhaust fumes can kill. Operate this unit only in a well ventilated area outdoors.
- Wear safety glasses or goggles that are marked as meeting ANSI Z87.1 standards, and ear/hearing protection when operating this unit. Wear a face or dust mask if the operation is dusty.
- Wear heavy, long pants, boots, gloves and long sleeve shirt. Do not wear, short pants, sandals or go barefoot.
- To reduce the risk of injury associated with objects being drawn into rotating parts, do not wear loose clothing, jewelry, scarves, etc. Secure hair above shoulder level.
- Use the unit only in daylight or good artificial light.
- Keep outside surfaces free from oil and fuel.
- Be sure the tines are not in contact with anything before starting the unit.
- Avoid accidental starting. Be in the starting position whenever pulling the starter rope. The operator and unit must be in a stable position while starting. See Operating Your Cultivator.
- Use the right tool. Only use this tool for the purpose intended.
- Use extreme caution when reversing or pulling the unit towards you.
- Do not overreach, take extra care when working on steep slopes or inclines. Always keep proper footing and balance.
- Always hold the unit with both hands when operating. Keep a firm grip on the handlebar grips.
- Keep hands, face, and feet at a distance from all moving parts. Do not touch or try to stop the tines when they are rotating. Do not operate without guards in place.
- Do not touch the engine, muffler or gearbox. These parts get extremely hot from operation. When turned off they remain hot for a short time.
- Do not operate the engine faster than the speed needed to do the job. Do not run the engine at high speed when not in use.
- Always stop the engine when operation is delayed or when walking from one location to another.
- Do not force unit. It will do the job better and with less likelihood of injury at a rate for which it was designed.

CHILDREN

- Tragic accidents can occur if the operator is not alert to the presence of small children. Children are often attracted to the tilling activity. Never assume that children will remain where you last saw them.
- Keep children out of the work area and under the watchful eye of a responsible adult other than the operator.
- Be alert and turn the unit off if a child enters the area.
- Never allow children under the age of 15 to operate the cultivator.

SERVICE

- Use extreme care in handling gasoline and other fuels. They are extremely flammable and the vapors are explosive.
- Store fuel only in containers specifically designed and approved for the storage of such materials.
- Avoid creating a source of ignition for spilled fuel. Do not start the engine until fuel vapors dissipate.
- Always stop the engine and allow it to cool before filling the fuel tank. Never remove the cap of the fuel tank, or add fuel, when the engine is hot. Never operate the unit without the fuel cap securely in place. Loosen the fuel tank cap slowly to relieve any pressure in the tank.
- Mix and add fuel in a clean, well-ventilated area outdoors where there are no sparks or flames. Slowly remove the fuel cap only after stopping engine. Do not smoke while fueling or mixing fuel. Wipe up any spilled fuel from the unit immediately.
- Move the unit at least 30 feet (9.1 m) from the fueling source and site before starting the engine. Do not smoke, keep sparks and open flames from the area while adding fuel or operating the unit.
- Stop the engine for maintenance, repair, to install or remove the tines. The unit must be stopped and the tines no longer turning to avoid injury.
- The tines become very sharp from use. Always wear heavy gloves when handling, removing, installing or cleaning the tines.
- Use only replacement parts and accessories approved by the manufacturer for this unit. These are available from your authorized service dealer. Use of any non approved parts or accessories could lead to serious injury to the user, or damage to the unit, and void your warranty.
- This unit has a clutch. The tines remain stationary when the engine is idling. If they do not, have the unit adjusted by an authorized service technician.
- Keep unit clean of vegetation and other materials. They may become lodged between the tines and gearbox or guard.
- To reduce fire hazard, replace faulty muffler and spark arrestor, keep the engine and muffler free from grass, leaves, excessive grease or carbon build up.
- Never store the unit, with fuel in the tank, inside a building where fumes may reach an open flame or spark.
- Allow the engine to cool before storing or transporting. Be sure to secure the unit while transporting.
- Store the unit in a dry place, either locked up or up high to prevent unauthorized use or damage. Keep out of the reach of children.
- Clean the tines with a hose and water. Wipe the tines with a light machine oil to prevent rust.
- Never douse or squirt the engine with water or any other liquid. Keep handles dry, clean and free from debris. Clean after each use, see Off-Season Storage.
- Keep these instructions. Refer to them often and use them to instruct other users. If you loan someone this unit, also loan them these instructions.



WARNING – YOUR RESPONSIBILITY: Restrict the use of this power machine to persons who read, understand and follow the warnings and instructions in this manual and on the machine.



- **WARNING - READ OPERATOR'S MANUAL**

Read the Operator's Manual(s) and follow all warnings and safety instructions. Failure to do so can result in serious injury to the operator and/or bystanders.



- **WEAR EYE AND HEARING PROTECTION**

Thrown objects and loud noise can cause severe eye injury and hearing loss. Wear eye protection meeting ANSI Z87.1 standards and ear protection when operating this unit.



- **KEEP BYSTANDERS AWAY**

Keep all bystanders, especially children and pets, at least 50 feet (15 m) from the operating area.



- **THROWN OBJECTS CAN CAUSE SEVERE INJURY**

Do not operate unit without proper attachments and guards in place.



- **HOT SURFACE WARNING**

Do not touch a hot muffler, cylinder or gearbox. You may get burned. These parts get extremely hot from operation. When turned off they remain hot for a short time.



- **CULTIVATORS – ROTATING TINES CAN CAUSE SEVERE INJURY**

Stop the engine and allow the tines to stop before installing or removing tines, or before cleaning or performing any maintenance. Keep hands and feet away from rotating tines.

SECTION 2: ASSEMBLING YOUR CULTIVATOR

Your yard and garden cultivator has been completely assembled except for the handlebar, throttle cable and wheel bracket assembly. A large phillips screwdriver is needed for assembly.

Removing Unit From Carton

1. Carefully unpack the contents and insure that nothing is damaged. Unwrap the throttle cable without bending or kinking it.



WARNING: Do not cut the plastic strap off the handle bar. The strap is under tension and can cause serious personal injury if cut.

2. Squeeze the handle bar and slide the plastic strap down and off. See Figure 1.

NOTE: Do not squeeze the handlebar too tight. Excessive squeezing can cause the handlebar to kink.

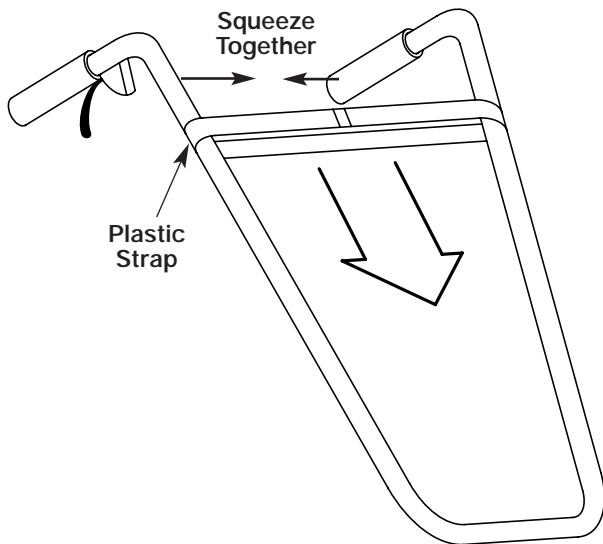

Figure 1

SETTING UP YOUR CULTIVATOR

Installing The Wheel Bracket Assembly



WARNING: To avoid injury from the tines, wear heavy gloves and a long sleeve shirt when installing the wheel bracket assembly.

1. With the unit on it's side, place the wheel bracket assembly on the underside of the tine guard. See Figure 2.
2. Install a carriage bolt through each of the slotted holes in the wheel bracket and into the tine guard.
3. On the top side of the tine guard, install a lock washer and a wing nut onto each of the bolts. See Figure 2.
4. Make sure the square shoulder of the bolts are through the slotted holes in the wheel bracket. Tighten the wing nuts. See Figure 3.

NOTE: Do not over tighten the wing nuts. Loosening the wing nuts allow the wheel height to be adjusted.

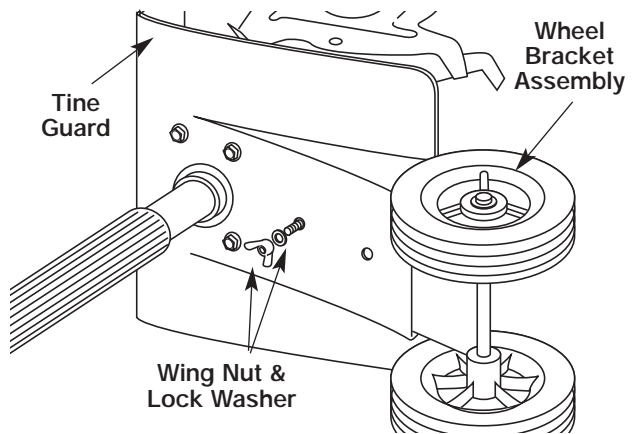

Figure 2

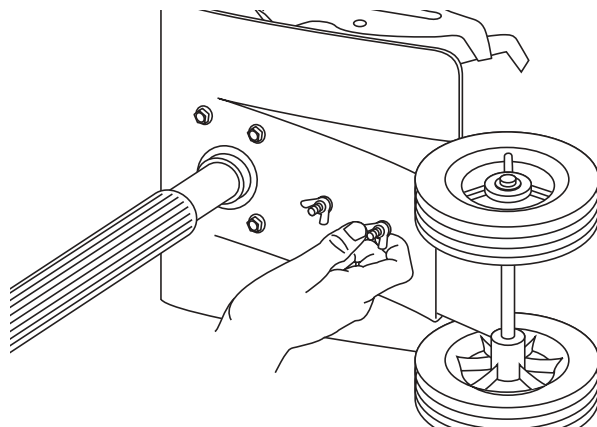

Figure 3

Installing The Handlebar

1. Position the mounting brackets by rotating them until the foot on the bracket rests against the engine. See Figure 4.
2. Place the handlebar between the bottom and middle clamp pieces. See Figure 5.
3. While holding the three pieces together, position the handlebar underneath the shaft tube and align with the top clamp.

NOTE: The holes in the clamp assembly will line up only when assembled correctly.

4. One at a time, hold a hex nut in the bottom clamp recess with a finger and install a screw through the clamp assembly. Start screw with a large Phillips screwdriver. Do the same with the other three (3) nuts and screws. Do not tighten until you make the handle adjustment.
5. Position the two (2) handlebar clamps with one on each side near the top of the handlebar. Swing the handlebar up until it sets to the outside of the two mounting brackets on the engine. See Figure 6.

NOTE: Positioning the handlebar onto the mounting brackets may require slightly spreading the handlebar.

6. Slide the two (2) handlebar clamps down over the mounting brackets. See Figure 7.

NOTE: It may be required to loosen or remove the thumb screws on the handlebar clamps to spread them to fit over the mounting brackets.

7. Center the handlebar and tighten the two (2) mounting bracket clamps and the four (4) handlebar clamp screws evenly until the handlebar is secure. See Figures 7 and 8.

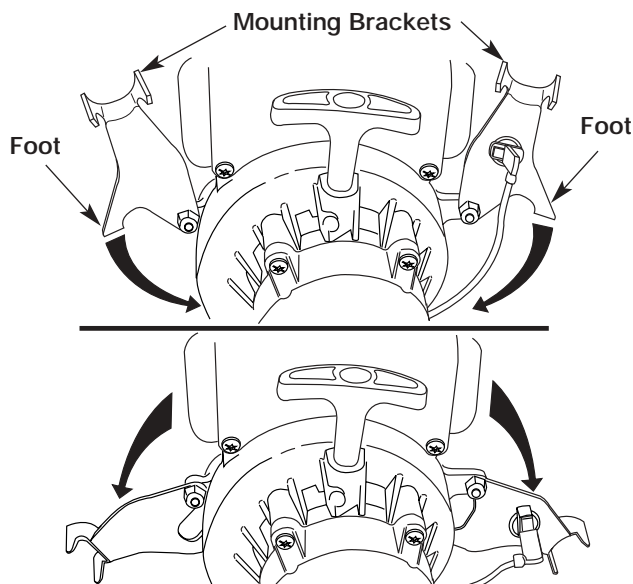

Figure 4

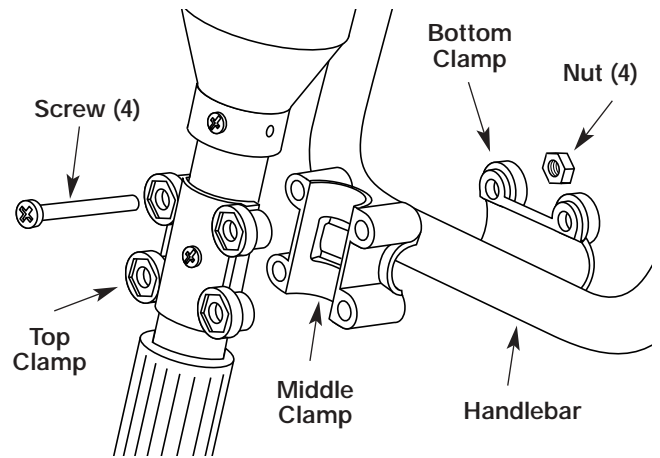

Figure 5

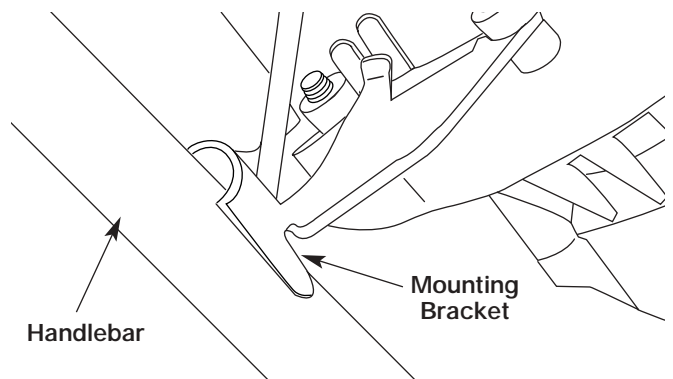

Figure 6

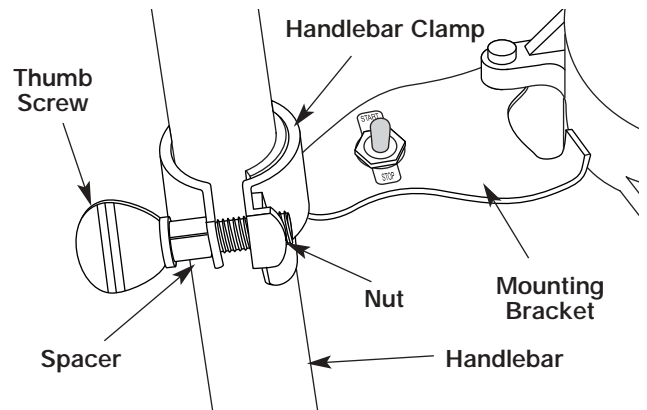

Figure 7

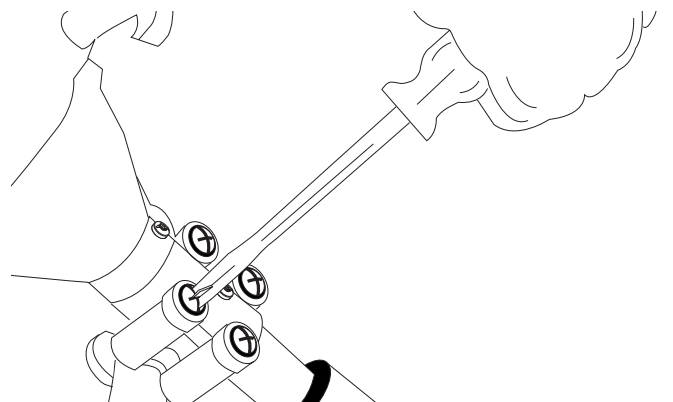

Figure 8

Throttle Cable Assembly

1. Wrap the throttle wire once around the handlebar. See Figure 9.
2. Depress the throttle trigger and locate hole for the throttle wire. See Figure 10.
3. With the throttle trigger depressed, place the barrel end of the throttle wire inside the hole of the trigger. See Figure 11.
4. Release the throttle trigger and guide the cable up into the slot of the trigger housing. See Figure 12.
5. Push the throttle cable housing into the trigger housing until it snaps into place. See Figure 12.
6. Route the throttle cable through the clip on the right handlebar mounting bracket. See Figure 13.

NOTE: Ensure the throttle cable is fitting into the guide at the carburetor plate on the engine. If it does not, the throttle will not work properly. See Figure 9.

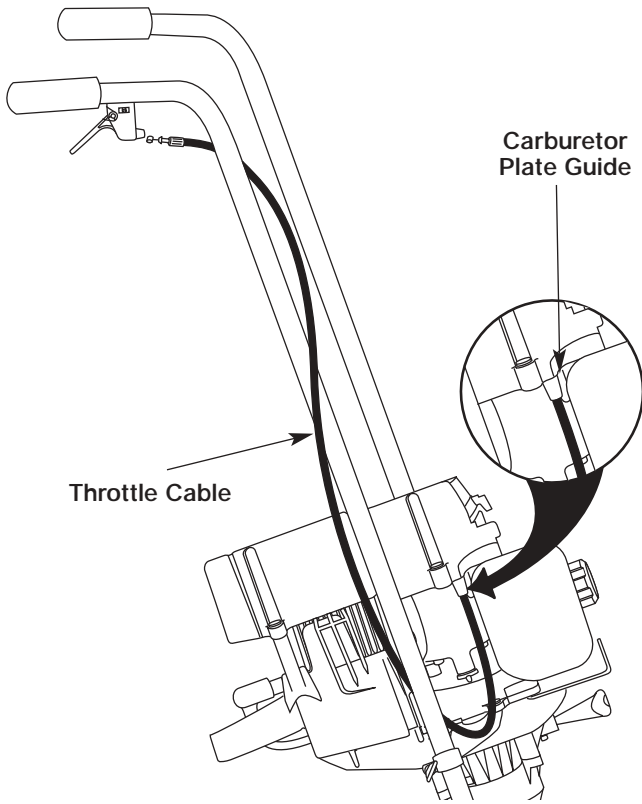

Figure 9

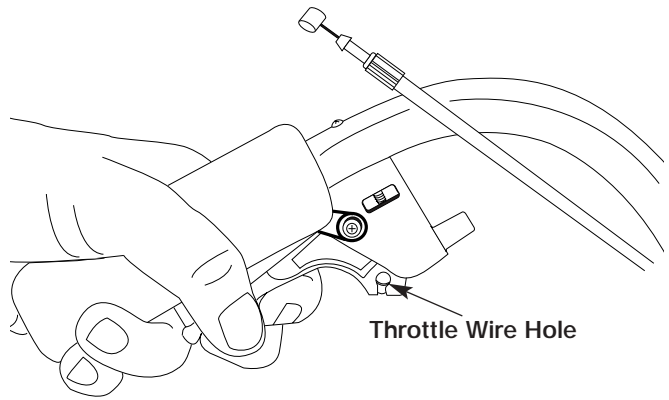

Figure 10

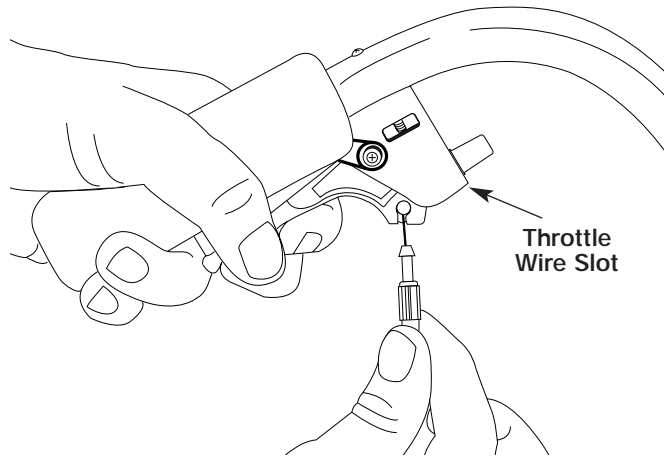

Figure 11

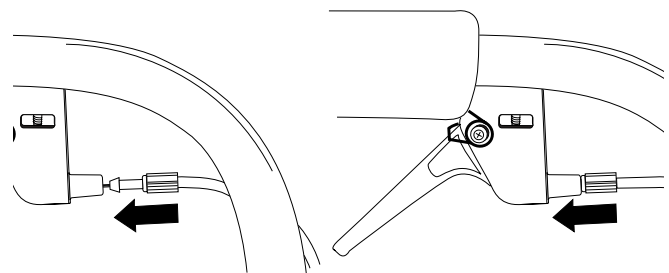

Figure 12

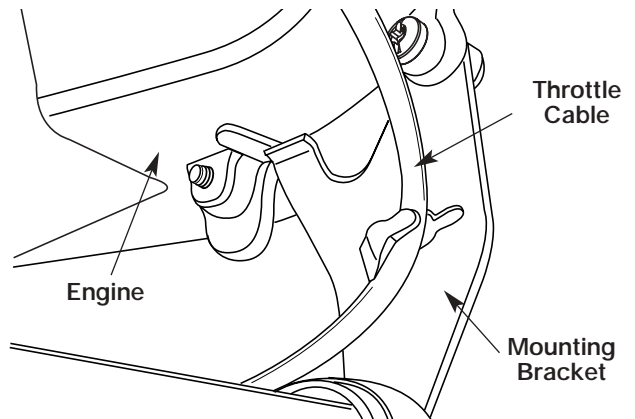

Figure 13

SECTION 3: KNOW YOUR CULTIVATOR

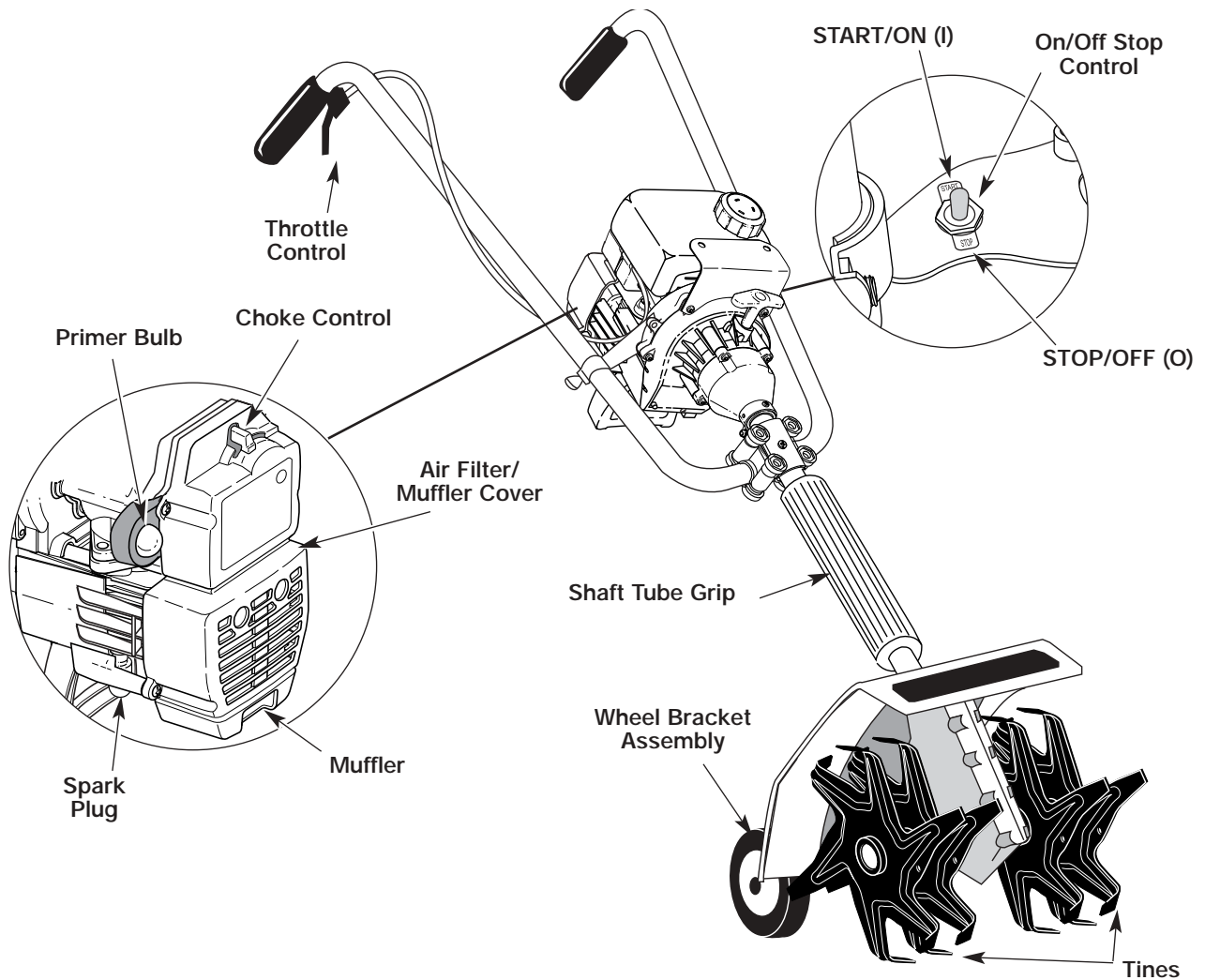

Figure 14

Read this operator's manual and safety rules before operating your cultivator. Compare illustrations in Figure 14 with your cultivator to familiarize yourself with the location of various controls and adjustments. Save this manual for future reference.

Application

Use this unit for tilling sod and light to medium soil. Also for tilling in garden areas, around trees, etc.

Throttle Control

The throttle control trigger is located below the right handlebar grip. It controls the engine speed. See Figure 14.

On/Off Stop Control

The On/Off Stop control switch is located on the left side mounting bracket. It is used to turn the unit on and off. The switch must be in the START position to start the unit. See Figure 14.

Choke Control

The choke control is located above the air filter/muffler cover. It is used to enrich the fuel mixture when starting a cold engine. See Figure 14.

Primer Bulb

The primer bulb is located to the left of the air filter/muffler cover. It is used to draw fuel into the carburetor when starting a cold engine or after refueling the unit. See Figure 14.

Wheel Bracket Assembly

The wheel bracket assembly is used to help move the unit when not in use and control the tilling depth when in use. Refer to OPERATING YOUR CULTIVATOR in Section 4.

Tines

The tilling tines are used to cultivate, furrow, and prepare your garden for seeding.

SECTION 4: OPERATING YOUR CULTIVATOR

Oil and Gas Mixing Instructions

Old and/or improperly mixed fuel are the main reasons for the unit not running properly. Be sure to use fresh, clean unleaded fuel. Follow the instructions carefully for the proper fuel/oil mixture.

Definition of Blended Fuels

Today's fuels are often a blend of gasoline and oxygenates such as ethanol, methanol or MTBE (ether). Alcohol-blended fuel absorbs water. As little as 1% water in the fuel can make fuel and oil separate. It forms acids when stored. When using alcohol-blended fuel, use fresh fuel (less than 60 days old).

Using Blended Fuels

If you choose to use a blended fuel, or its use is unavoidable, follow recommended precautions.

- Always use fresh fuel mix per your operator's manual.
- Use the fuel additive STA-BIL® or an equivalent.
- Always agitate the fuel mix before fueling the unit.
- Drain the tank and run the engine dry before storing the unit.

Using Fuel Additives

The use of fuel additive, such as STA-BIL® Gas Stabilizer or an equivalent, will inhibit corrosion and minimize the formation of gum deposits. Using a fuel additive can keep fuel from forming harmful deposits in the carburetor for up to six (6) months. Add 0.8 oz. (23 ml.) of fuel additive per gallon of fuel according to the instructions on the container. NEVER add fuel additives directly to the unit's fuel tank.



CAUTION: For proper engine operation and maximum reliability, pay strict attention to the oil and fuel mixing instructions on the 2-cycle oil container. Using improperly mixed fuel can severely damage the engine.

Thoroughly mix the proper ratio of 2-cycle engine oil with unleaded gasoline in a separate fuel can. Use a 32:1 fuel/oil ratio. Do not mix them directly in the engine fuel tank. See Figure 15 for specific gas and oil mixing ratios.

NOTE: Two gallons (7.6 liters) of unleaded gasoline mixed with one 8 oz. (236 ml.) bottle of Arnold 2 Cycle Oil makes a 32:1 fuel/oil ratio OR one gallon (3.8 liters) of unleaded gasoline mixed with one 4 oz. (120 ml.) bottle of Arnold 2 Cycle Oil makes a 32:1 fuel/oil ratio.



+



UNLEADED GAS

ARNOLD 2 CYCLE OIL

2 US. GALLONS
(7.6 LITERS)

+ 8.0 FL. OZ.
(236 ml)

OR

1 US. GALLON
(3.8 LITERS)

+ 4.0 FL. OZ.
(120 ml)

MIXING RATIO - 32:1

Figure 15



WARNING: Gasoline is extremely flammable. Ignited Vapors may explode. Always stop the engine and allow it to cool before filling the fuel tank. Do not smoke while filling the tank. Keep sparks and open flames at a distance from the area.



WARNING: Remove fuel cap slowly to avoid injury from fuel spray. Never operate the unit without the fuel cap securely in place.



WARNING: Add fuel in a clean, well ventilated area outdoors. Wipe up any spilled fuel immediately. Avoid creating a source of ignition for spilt fuel. Do not start the engine until fuel vapors dissipate.

NOTE: Dispose of the old fuel/oil mix in accordance to Federal, State, and Local regulations.

Filling The Fuel Tank

Fill or add fuel to the tank only when the cultivator is in a horizontal position. See figure 16.

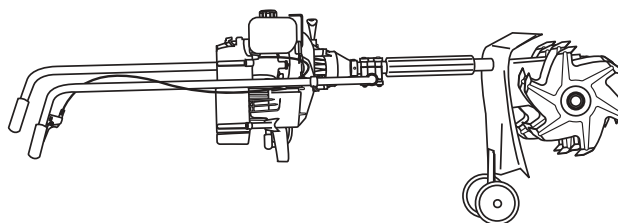

Figure 16

Starting Engine



WARNING: Avoid accidental starting. Be in the starting position when pulling the starter rope. See Figure 19. The operator and unit must be in a stable position while starting to avoid serious personal injury.

WARNING: Operate this unit only in a well ventilated area outdoors. Carbon monoxide exhaust fumes can be lethal in a confined area.

1. Mix gas with oil. Fill fuel tank with fuel/oil mixture. See Oil and Gas Mixing Instructions.
2. Put the On/Off Stop Control in the START (I) position. See Figure 17.
3. Fully press and release primer bulb slowly 5 to 7 times. Fuel should be visible in the bulb. If fuel is not visible, press three (3) more times, or until it is. See Figure 18.
4. Place the choke lever in the FULL choke position (A |←|). See Figure 18.
5. With the unit on the ground, squeeze the throttle control and pull starter rope briskly. See Figure 18. Continue pulling until the engine sounds as though it wants to run (normally 2 to 5 pulls).

NOTE: Squeeze the throttle control until the engine has started and warmed up.

6. Place the choke lever in the PARTIAL choke position (B |←|). See Figure 18.

NOTE: The unit will not run in the FULL choke position (A |←|).

7. Pull starter rope briskly 1 to 3 times to start the engine. See Figure 19.
8. If the engine does not start, repeat steps 4 through 7.

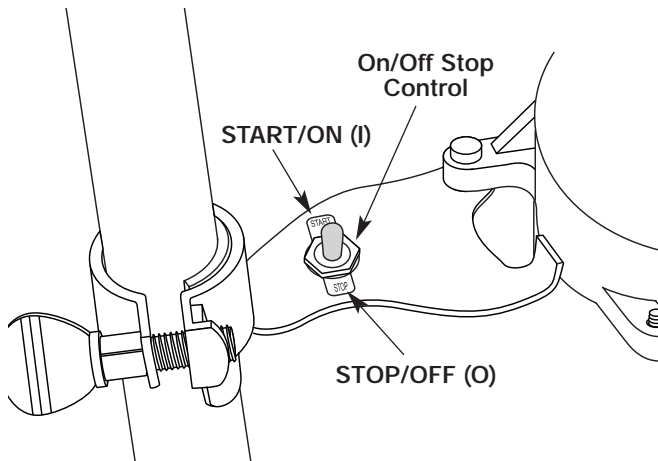

Figure 17

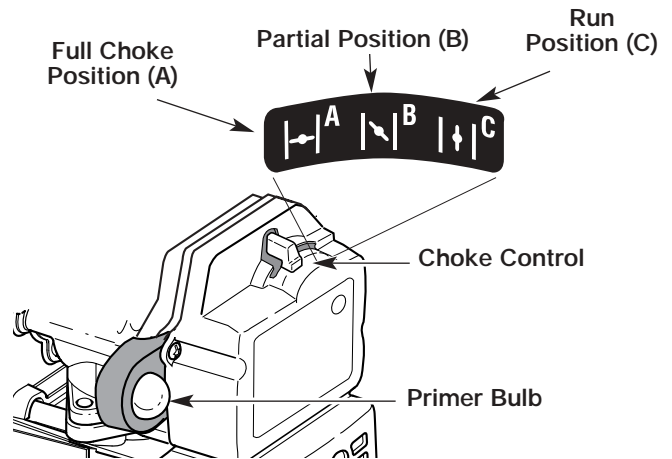

Figure 18

NOTE: If the engine floods while trying to start, place the choke lever in the RUN position (C |←|). Squeeze the throttle control. Pull the starter rope briskly. The engine should start within three (3) to eight (8) pulls.

9. Squeeze the throttle control to warm up engine for 5 to 10 seconds. Place the choke lever in the RUN position (C |←|). See Figure 18.

NOTE: Choking is unnecessary when starting a warm engine. Put the On/Off Stop Control in the START (I) position and start in PARTIAL Choke position (B |←|). See Figures 17 and 18.

To Stop Engine

1. Release your hand from the throttle control. See Figure 19. Allow the engine to cool down by idling.
2. Put the On/Off Stop Control in the STOP (O) position. See Figure 17.

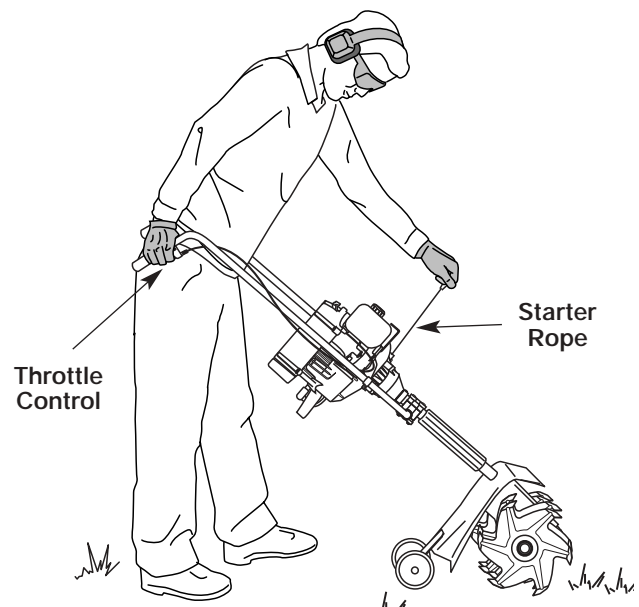

Figure 19

Using Your Cultivator



WARNING: Dress properly to reduce the risk of injury when operating this unit. Do not wear loose clothing or jewelry. Wear eye and ear/hearing protection. Wear heavy, long pants, boots and gloves. Do not wear short pants, sandals or go barefoot.

1. Move the cultivator to the work area prior to starting the engine. The cultivator may be transported by pushing it on wheels or carrying it by the shaft tube grip.



WARNING: To prevent serious personal injury, never pick-up or carry the unit while the engine is running.

2. Start the unit per Starting Instructions.
3. With the engine running and the tines off the ground, depress the throttle control to increase the engine speed.
4. Holding both of the handlebar grips firmly, slowly lower the cultivator until the tines make contact with the ground. See Figure 20.
5. As cultivating action begins, pull back on the cultivator so that the tines can penetrate the ground.
6. Once the ground has been broken, continue at a moderate pace until you are familiar with the controls and the handling of the cultivator.
7. Pull the cultivator backwards to improve the depth of cultivation and reduce your effort.
8. If the tines are digging too deep or not deep enough, adjust the tines per Adjusting Tine Depth.



Figure 20

Adjusting Tine Depth

Tine adjustment will vary depending on the type of soil being cultivated and how it will be used. Generally, adjusting the tines to break the soil 4 to 6 inches is recommended for most gardens. Adjust the tines as follows:



WARNING: To prevent serious injury, never do adjustments, maintenance or repairs with unit running. Disconnect spark plug wire to ensure the unit will not start.

1. Stop the engine and disconnect the spark plug wire.
2. Loosen (do not remove) the two wing nuts on the tine guard. See Figure 20.
3. Slide the wheel bracket assembly down for shallower and up for deeper tine penetration.
4. Once the tines are in the desired position, tighten the wing nuts, making sure that the carriage bolts are seated properly through the bracket.
5. If the tine depth is not correct, repeat steps 2 to 4.
6. Reconnect the spark plug wire.

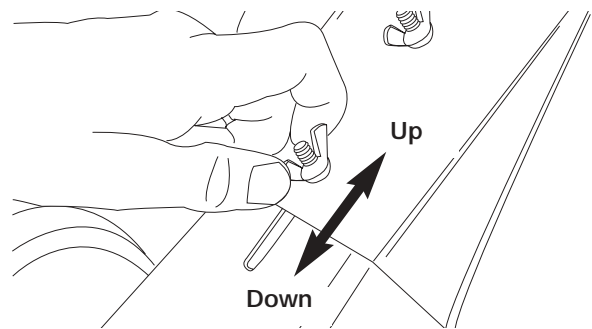

Figure 20

Transporting the Unit



WARNING: To prevent serious personal injury, always stop the engine when operation is delayed or when transporting the unit from one location to another.

1. Stop the engine.
2. Slide the wheel bracket assembly all the way down.
3. Tilt the unit back until the tines clear the ground.
4. Push or pull the unit to the next location to be cultivated.

NOTE: The cultivator can also be carried by the shaft tube grip. See Figure 21.

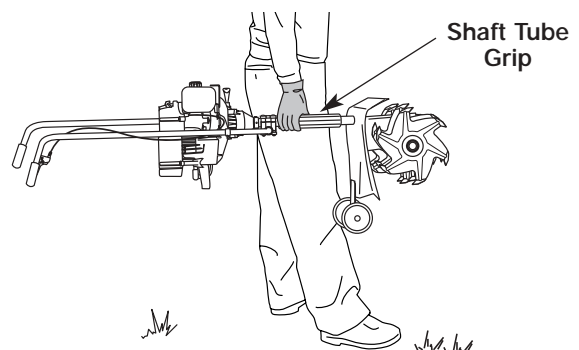

Figure 21

SECTION 5: MAKING ADJUSTMENTS



WARNING: To prevent serious injury, never do adjustments, maintenance or repairs with unit running. Always do maintenance and repairs on a cool unit. Disconnect spark plug wire to ensure the unit will not start.

Wheel Adjustments

To adjust the wheel height, refer to OPERATING YOUR CULTIVATOR in Section 4.

Carburetor Adjustments



WARNING: If any adjustments are made to the engine while the engine is running (e.g. carburetor), keep clear of all moving parts. Be careful of heated surfaces and muffler.

The idle speed adjuster of the engine is adjustable through the air filter/muffler cover. See Figure 22.

NOTE: Careless adjustments can seriously damage your unit. An authorized service dealer should make carburetor adjustments.

Check Fuel Mixture

Old and/or improperly mixed fuel is usually the reason for the unit not running properly. Drain and refill the tank with fresh, properly mixed fuel prior to making any adjustments. Refer to OPERATING YOUR CULTIVATOR in Section 4.

Clean Air Filter

The condition of the air filter is important to the operation of the unit. A dirty air filter will restrict air flow and change the air/fuel mixture. This is often mistaken for an out of adjustment carburetor. Check the condition of the air filter before adjusting the idle speed adjuster. Refer to MAINTAINING YOUR CULTIVATOR in Section 6.

Adjusting Idle Speed



WARNING: This unit will need to be running during idle speed adjustment. Wear protective clothing and observe all safety instructions to prevent serious personal injury.

If after checking the fuel mixture and cleaning the air filter the engine still will not idle, adjust the idle speed screw as follows.

1. Start the engine and let it run about 2-3 minutes at a high idle to warm up. Refer to OPERATING YOUR CULTIVATOR in Section 4.

NOTE: Ensure the tines are not in contact with the ground when adjusting the idle.

2. Release the throttle control and let the engine idle. If the engine stops, insert a small phillips or flat blade screwdriver into the hole in the air filter/muffler cover. Turn the idle speed screw in, clockwise, 1/8 of a turn at a time (as needed) until the engine idles smoothly. See Figure 22.

NOTE: The tines should not rotate when the engine idles.

3. If the tines rotate when the engine idles, turn the idle speed screw counterclockwise 1/8 of a turn at a time (as needed), to reduce idle speed.

Checking the fuel mixture, cleaning the air filter, and adjusting the idle speed screw should solve most engine problems.

If not and:

- The engine will not idle,
- The engine hesitates or stalls on acceleration,
- There is a loss of engine power,

have the carburetor adjusted by an authorized service dealer.

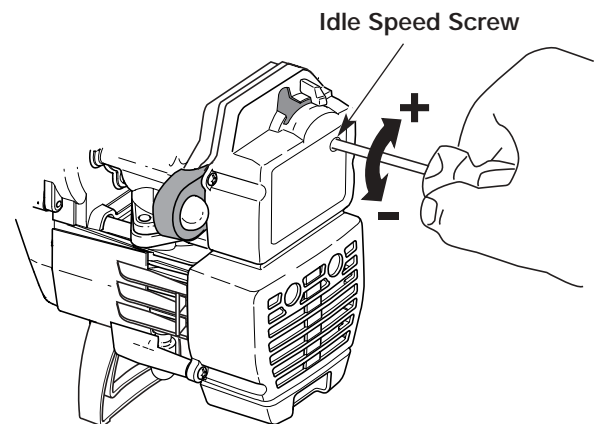

Figure 22

Engine Specifications

Engine TypeAir-Cooled, 2-Cycle
Displacement 31cc
Idle Speed R.P.M. 2,800-3,600 rpm
Operating R.P.M. 6,700-9,000 rpm
Fuel/Oil Mixture Ratio. 32:1

SECTION 6: MAINTAINING YOUR CULTIVATOR

Maintenance Schedule

These required maintenance procedures should be performed at the frequency stated in the table. They should also be included as part of any seasonal tune-up.

FREQUENCY

Before Starting Engine

Every 10 Hours

Every 50 Hours or Seasonal

MAINTENANCE REQUIRED

Fill fuel tank with correct oil and fuel mixture.

Clean and re-oil air filter.

Check spark plug condition and gap.



WARNING: To avoid serious personal injury, always turn the unit off, allow it to cool and disconnect the spark plug before you clean or perform any maintenance on it.

Lubrication

Gearbox-The gearbox is pre-lubricated and sealed at the factory.

Trouble Shooting

Refer to the trouble shooting chart for more information.

Engine

IMPORTANT: Never run your engine without air cleaner completely assembled.

Air Filter Maintenance

1. Place the choke control in the PARTIAL choke position (B).

NOTE: The choke control must be in the PARTIAL choke position (B) to remove the air filter/muffler cover. See Figure 23.

2. Remove the four (4) screws securing the air filter/muffler cover. See Figure 23. Use a flat blade or # T20 Torx bit screwdriver.
3. Pull the cover from the engine. Do not force.
4. Remove the air filter from behind the air filter/muffler cover. See Figure 24.
4. Wash the filter in detergent and water. Rinse the filter thoroughly. Squeeze out excess water. Allow it to dry completely.
5. Apply enough clean SAE 30 oil to lightly coat the filter. See Figure 25.
6. Squeeze the filter to spread and remove excess oil. See Figure 25.

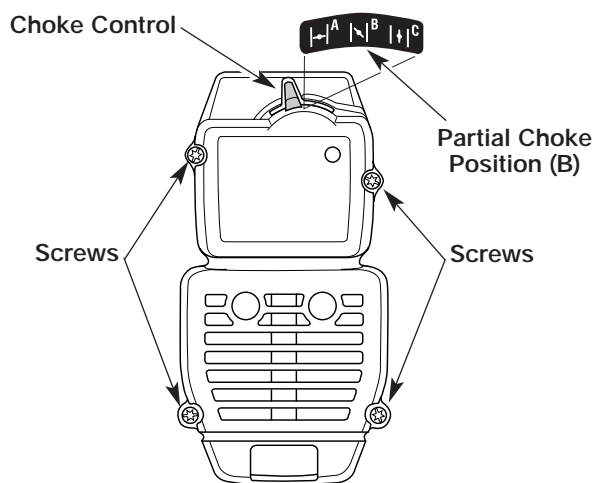

Figure 23

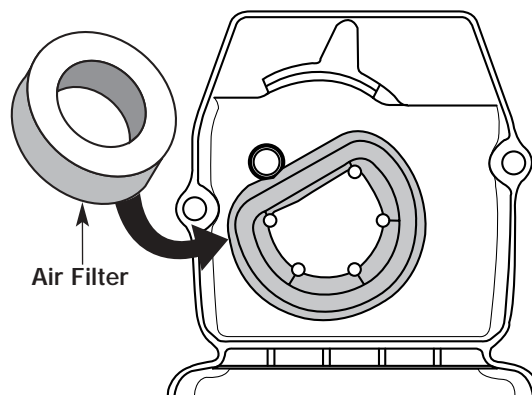

Figure 24

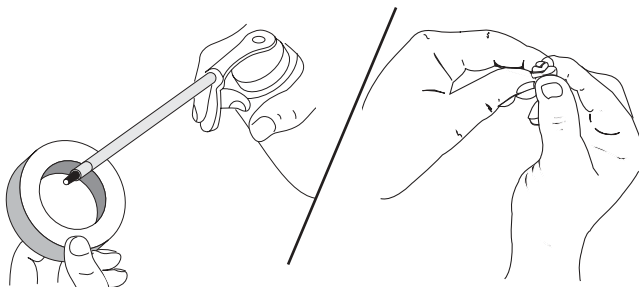

Figure 25

- Replace the air filter inside the air filter/muffler cover. See Figure 24.

NOTE: Operating the unit without the air filter and air filter/muffler cover assembly, will VOID the warranty.

- Place the air filter/muffler cover over the back of the carburetor and muffler.

NOTE: The choke control must be in the PARTIAL choke position (B) to install the air filter/muffler cover. See Figure 23.

- Insert the four (4) screws into the holes in the air filter/muffler cover and tighten. See Figure 23. Use a flat blade or # T20 Torx bit screwdriver. Do not over tighten. Do not force.

Replacing The Spark Plug

Use a Champion RDJ7Y spark plug (or equivalent). The correct air gap is 0.020 inch (0.5 mm). Remove the plug after every 50 hours of operation to check its condition.

- Stop the engine and allow it to cool. Grasp the plug wire firmly and pull the cap from the spark plug.
- Clean dirt from around the spark plug. Remove the spark plug from the cylinder head by turning a 5/8 in. socket counterclockwise.

NOTE: Replace cracked, fouled or dirty spark plug.

- Set the air gap at 0.020 inch (0.5 mm) using a feeler gauge. See Figure 26.



CAUTION: Do not sand blast, scrape, or clean electrodes. Grit in the engine could damage the cylinder.

- Install a correctly gapped spark plug in the cylinder head. Tighten by turning the 5/8 inch socket clockwise until snug.

If using a torque wrench torque to:

110-120 in. • lb. (12.3-13.5 N • m).

Do not over tighten.

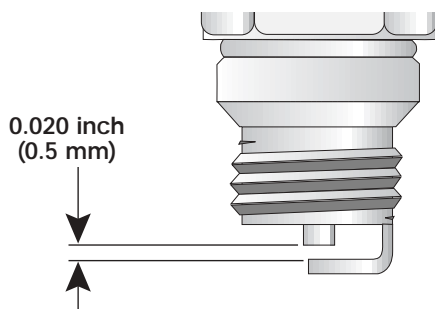

Figure 26

Tine Removal And Replacement

All 4 tines should be replaced at the same time because they will wear evenly through normal use. Work on one side at a time.



WARNING: To prevent serious personal injury, always wear heavy gloves when handling the tines.

- Put the On/Off Stop Control in the STOP (O) position and disconnect the spark plug wire.
- Remove the clevis pin clips and clevis pins. See Figure 27.
- Remove the tines and felt cushions from the shaft.
- Clean and oil the shaft.
- The tines are stamped with the letter "R" or "L" to identify their position on each side of the gearbox when facing the front of the unit.
- Replace the tines and felt cushions onto the shaft with the hubs on the tines facing each other.
- Ensure the tips on tines are aligned in the same direction with each other before reinstalling the clevis pins and pin clips. See Figure 28.
- Repeat this procedure on the opposite side.

NOTE: When installed correctly, there will be an "R" and "L" tine on each side of the gearbox and the tips on the tines line up in the same direction. It is important that the tines are installed correctly.

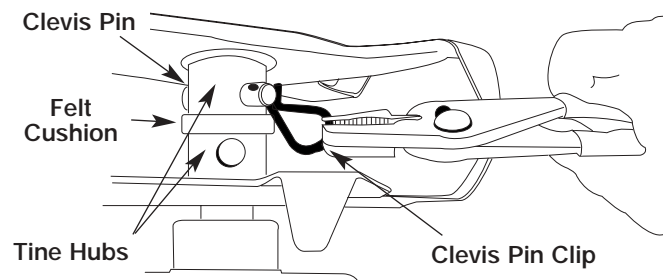

Figure 27

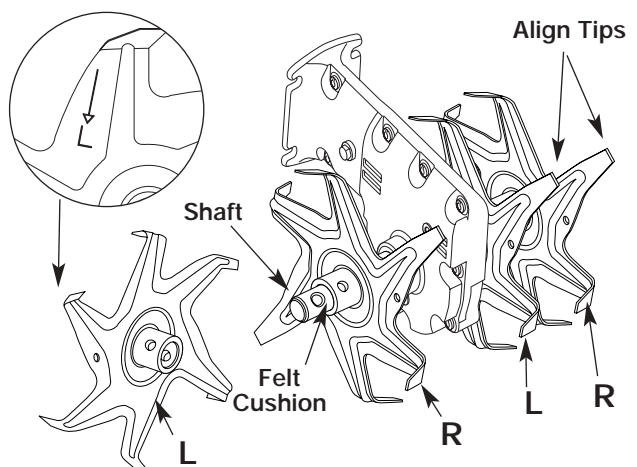

Figure 28

SECTION 7: OFF SEASON STORAGE

If the unit will be stored for an extended time,

1. Drain all fuel from the fuel tank into a container. Do not use fuel that has been stored for more than 60 days. Dispose of the old fuel in accordance to local regulations.
2. Start the engine and allow it to run until it stalls. This ensures that all fuel has been drained from the carburetor.
3. Allow the engine to cool. Remove the spark plug and put 1 oz. (30 ml) of high quality motor oil into the cylinder. Pull the starter rope slowly to distribute the oil. Reinstall the spark plug.

NOTE: Remove the spark plug and drain all of the oil from the cylinder before attempting to start the unit after storage.

4. Thoroughly clean the unit and inspect for any loose or damaged parts. Repair or replace damaged parts and tighten loose screws, nuts or bolts.
5. Wipe the tines with an oiled rag to prevent rust.

The unit is ready for storage.

- Never store the unit with fuel in the tank where fumes may reach an open flame or spark.
- Allow the engine to cool before storing.
- Store the unit in a locked up area to prevent unauthorized use or damage.
- Store the unit in a dry, well ventilated area. Do not store next to corrosive materials, such as fertilizer.
- Store the unit out of the reach of children.

SECTION 8: TROUBLE SHOOTING GUIDE

Trouble	Possible Cause(s)	Corrective Action
ENGINE WILL NOT START	On/Off Stop Control in the STOP position Empty fuel tank Primer bulb wasn't pressed enough Engine flooded Old or improperly mixed fuel Fouled spark plug	Turn the On/Off Stop Control to START Fill fuel tank Press primer bulb fully and slowly 5-7 times Use starting procedure with choke control in the RUN position Drain fuel tank / Add fresh fuel mixture Replace or clean the spark plug
ENGINE WILL NOT IDLE	Air Filter is Plugged Old or improperly mixed fuel Improper carburetor adjustment	Replace or clean the air filter Drain fuel tank / Add fresh fuel mixture Refer to MAKING ADJUSTMENTS, Section 5.
ENGINE WILL NOT ACCELERATE	Old or improperly mixed fuel Improper carburetor adjustment	Drain fuel tank / Add fresh fuel mixture Refer to MAKING ADJUSTMENTS, Section 5.
ENGINE LACKS POWER OR STALLS WHEN UNDER LOAD	Old or improperly mixed fuel Improper carburetor adjustment Cultivator tines bound with dirt or grass	Drain fuel tank / Add fresh fuel mixture Refer to MAKING ADJUSTMENTS, Section 5. Stop the unit, switch the On/Off Stop Control to STOP, clean and remove any debris binding the tines

SECTION 9: PARTS LIST FOR MODEL 21A-120R000

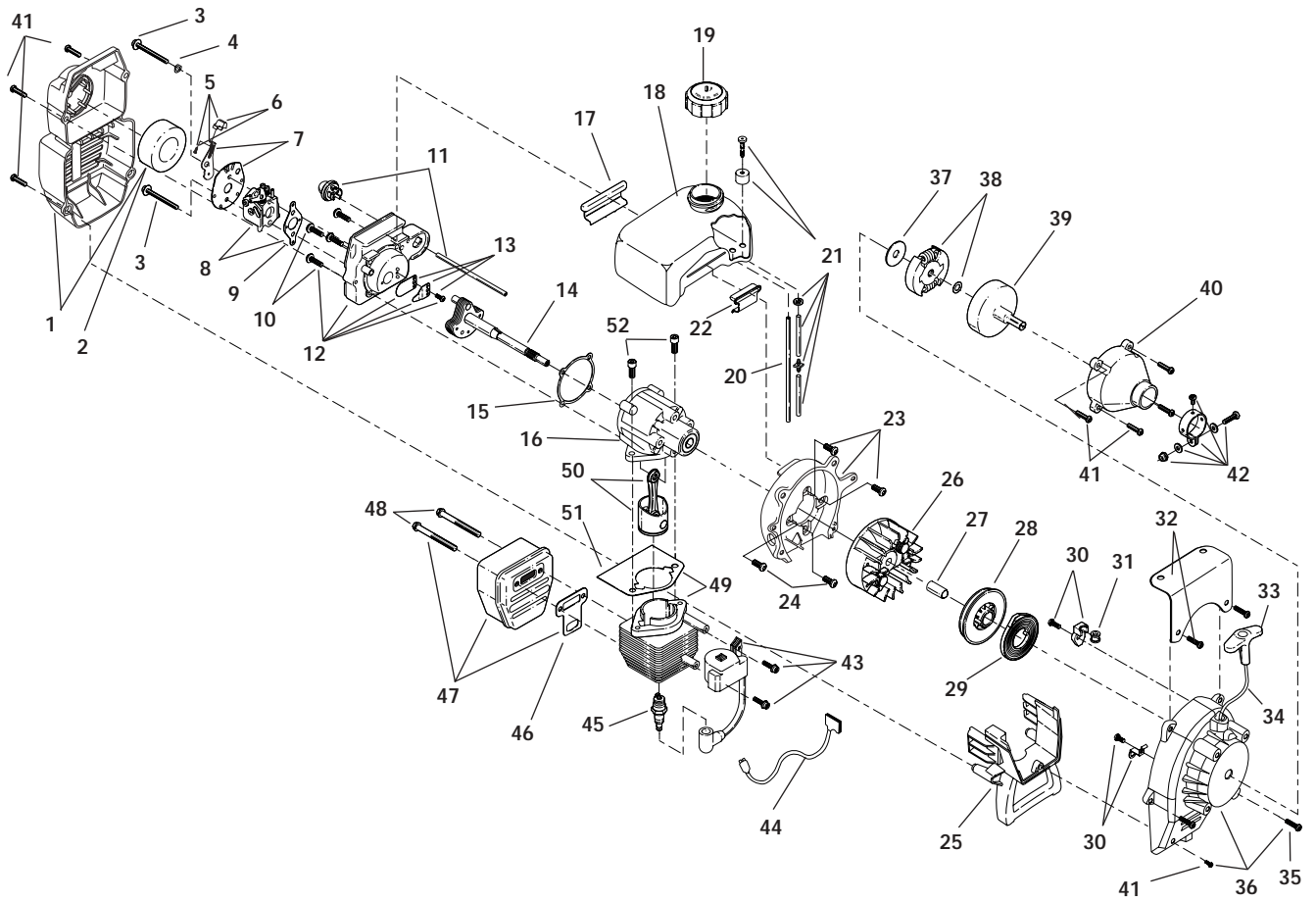

MODEL 21A-120R000

Ref. No.	Part No.	Part Description	Ref. No.	Part No.	Part Description
1.	182059	Air Cleaner/Muffler Cover Assembly (includes 2 & 41)	36	182776	Starter Housing Assembly (includes items 28-31, 33-35)
2.	180350	Air Cleaner Filter	37	182368	Clutch Washer
3.	180351	Carburetor Mounting Screw Assembly	38	182369	Clutch Rotor Assembly
4.	180226	Wavey Washer	39	153592	Clutch Drum Assembly
5.	182160	Choke Lever Assembly (includes 6)	40	180098	Clutch Cover Assembly (includes 41)
6.	182161	Choke Knob and Screw	41	181345	Clutch Cover Screw
7.	182162	Choke Lever and Plate (includes 5)	42	153597	Upper Clamp Assembly
8.	182062	Carburetor Assembly W/Limiter Caps (includes 9 & 21)	43	181937	Module Assembly
9.	610675	Carburetor Gasket	44	181580	Wire Lead
10.	181860	Carb Mount Screw	45	610311	Spark Plug
11.	181801	Primer and Hose Assembly	46	182065	Exhaust Gasket
12.	182063	Carb Mount Assembly (includes 10)	47	182174	Muffler Assembly (includes 46 & 48)
13.	684451	Reed Assembly	48	182464	Muffler Mounting Bolt Assembly
14.	182790	Power Shaft Assembly	49	181622	Cylinder Assembly (includes 51 & 52)
15.	612115	Carburetor Mount Gasket	50	684449	Piston and Rod Assembly
16.	182791	Crank Case Service Assembly (includes 10, 14 & 24)	51	610674	Cylinder Gasket
17.	612134	Rear Mounting Pad	52	182723	Cylinder Bolt
18.	180046	Fuel Tank Assembly (includes 19-21)	*	180011	Engine Gasket Kit
19.	181559	Fuel Cap Assembly	*	180602	O.E.M. Carburetor Repair Kit (Walbro)
20.	181168	Fuel Return Line	*	180090	O.E.M. Carburetor Repair Kit (Zama)
21.	682039	Fuel Line Assembly	*	181069	Gasket-Diaphragm Repair Kit (Walbro)
22.	145308	Front Mounting Pad	*	180091	Gasket-Diaphragm Repair Kit (Zama)
23.	683065	Shroud Assembly	*	180530	Piston Ring
24.	181861	Shroud Screw	*	182792	Short Block Assembly (includes 45, 49-52)
25.	182064	Shroud Extension and Stand	*	181501	Starter Housing Screw Set
26.	182736	Flywheel Assembly	*	181873	Carburetor Limiter Cap Set (Walbro)
27.	181065	Spacer	*	181562	Carburetor Limiter Cap Set (Zama)
28.	181597	Recoil Pulley Assembly	*	610309	Crankcase Seal
29.	613102	Recoil Spring	*	181599	Clutch Springs (Qty. 2)
30.	181441	Pulley Retainer Assembly	*	not shown	
31.	611061	Rope Guide			
32.	180317	Fuel Tank Guard Assembly			
33.	181079	Pull Handle			
34.	613103	Rope			
35.	181912	Housing Screw			

MODEL 21A-120R000

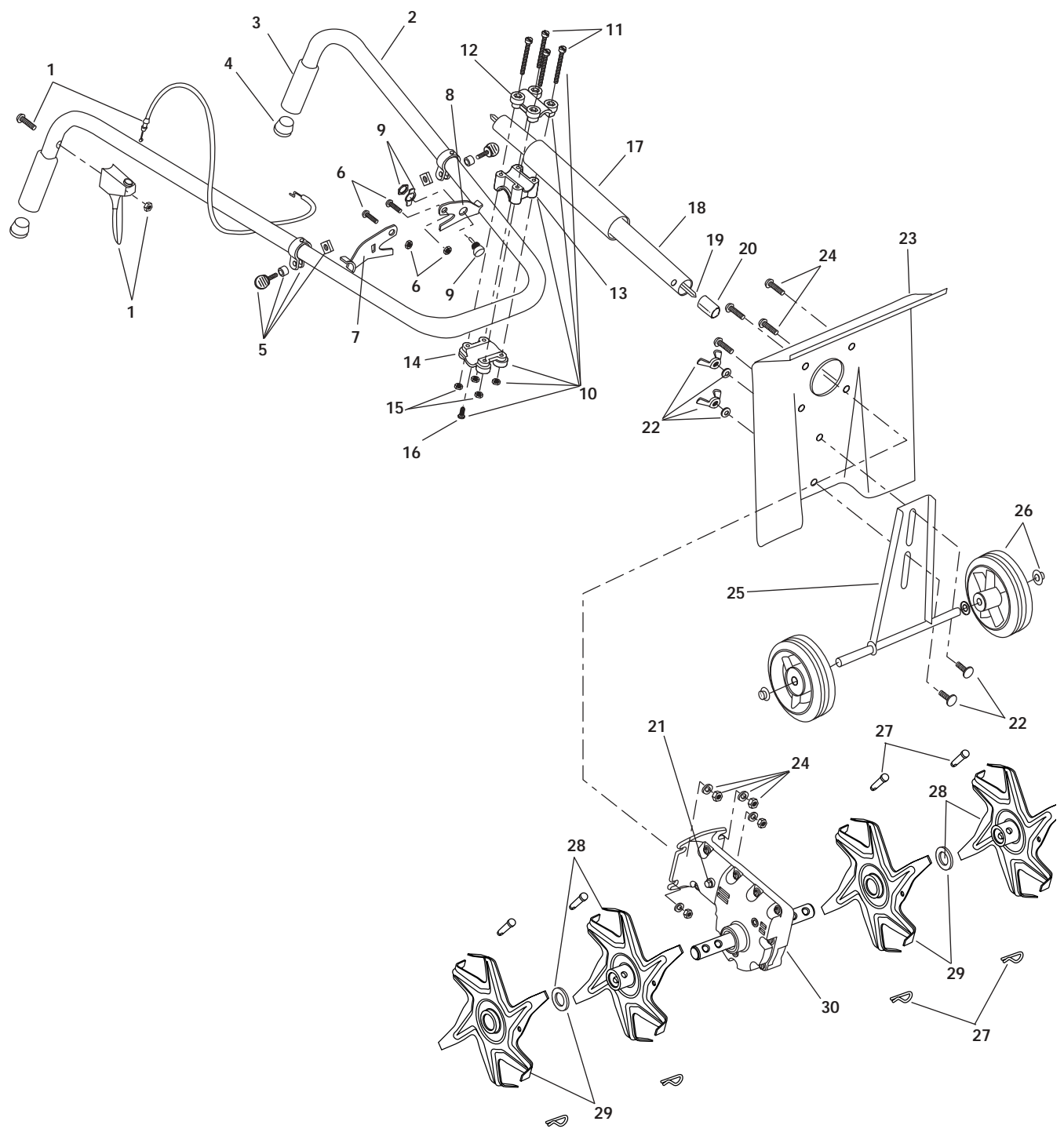

MODEL 21A-120R000

Ref. No.	Part No.	Part Description	Ref. No.	Part No.	Part Description
1	181573	Throttle Trigger and Cable Assembly	18	180943	Drive Shaft Housing Assembly
2	180942	Handle Bar w/Clamp Assemblies (includes 3-5)	19	181577	Flexible Drive Shaft
3	612831	Grip	20	181578	Retainer Sleeve (includes 21)
4	612021	Tube Closure	21	180288	Sleeve Retainer Bolt
5	181503	Clamp Assembly	22	147467	Wheel Bracket Mounting Hardware
6	147501	Engine Bracket Mounting Hardware	23	182781	Guard
7	181574	Engine Mount Bracket, R.H.	24	181579	Guard Mounting Hardware
8	181504	Engine Mount Bracket, L.H.	25	180320	Wheel Bracket Assembly
9	682035	Switch Assembly	26	180944	Wheel Assembly
10	683295	Handle Bracket Assembly (includes 11-16)	27	147473	Tine Fastener Assembly
11	181811	Screw	28	182729	Tine Assembly (Left Outer or Right Inner)
12	181812	Upper Handle Clamp	29	182730	Tine Assembly (Left Inner or Right Outer)
13	181813	Middle Handle Clamp	30	182750	Gear Box Assembly
14	181814	Lower Handle Clamp	*	182780	Arnold 2-Cycle Oil
15	181815	Nut			
16	145569	Anti-Rotation Screw	*	not shown	
17	181575	Grip			

MANUFACTURER'S LIMITED WARRANTY FOR:



The limited warranty set forth below is given by MTD SOUTHWEST INC ("MTD") with respect with new merchandise purchased and used in the United States, its possessions and territories.

MTD warrants this product against defects in material and workmanship for a period of two (2) years commencing on the date of original purchase and will, at its option, repair or replace, free of charge, any part found to be defective in material or workmanship. This limited warranty shall only apply if this product has been operated and maintained in accordance with the Operator's Manual furnished with the product, and has not been subject to misuse, abuse, commercial use, neglect, accident, improper maintenance, alteration, vandalism, theft, fire, water or damage because of other peril or natural disaster. Damage resulting from the installation or use of any accessory or attachment not approved by MTD for use with the product(s) covered by this manual will void your warranty as to any resulting damage. This warranty is limited to ninety (90) days from the date of original retail purchase for any MTD product that is used for rental or commercial purposes, or any other income-producing purpose.

HOW TO OBTAIN SERVICE: Warranty service is available, WITH PROOF OF PURCHASE THROUGH YOUR LOCAL AUTHORIZED SERVICE DEALER. To locate the dealer in your area, please check for a listing in the Yellow Pages or contact the Customer Service Department of MTD SOUTHWEST INC by calling 1-800-345-8746 or writing to 550 N. 54th Street, Chandler, Arizona 85226 or if in Canada call 1-800-668-1238. No product returned directly to the factory will be accepted unless prior written permission has been extended by the Customer Service Department of MTD SOUTHWEST INC.

This limited warranty does not provide coverage in the following cases:

- A. Tune-ups - Spark Plugs, Carburetor Adjustments, Filters
- B. Wear items - Starter Pulley, Starter Ropes, Tines
- C. MTD does not extend any warranty for products sold or exported outside of the United States of America, its possessions and territories, except those sold through MTD's authorized channels of export distribution.

MTD reserves the right to change or improve the design of any MTD Product without assuming any obligation to modify any product previously manufactured.

No implied warranty, including any implied warranty of merchantability or fitness for a particular purpose, applies after the applicable period of express written warranty above as to the parts as identified. No other express warranty or guaranty, whether written or oral, except as mentioned above, given by any person or entity, including a dealer or retailer, with respect to any product shall bind MTD. During the period of the Warranty, the exclusive remedy is repair or replacement of the product as set forth above. (Some states do not allow limitations on how long an implied warranty lasts, so the above limitation may not apply to you.)

The provisions as set forth in this Warranty provide the sole and exclusive remedy arising from the sales. MTD shall not be liable for incidental or consequential loss or damages including, without limitation, expenses incurred for substitute or replacement lawn care services, for transportation or for related expenses, or for rental expenses to temporarily replace a warranted product. (Some states do not allow limitations on how long an implied warranty lasts, so the above limitation may not apply to you.)

In no event shall recovery of any kind be greater than the amount of the purchase price of the product sold. Alteration of the safety features of the product shall void this Warranty. You assume the risk and liability for loss, damage, or injury to you and your property and/or to others and their property arising out of the use or misuse or inability to use the product.

This limited warranty shall not extend to anyone other than the original purchaser, original lessee or the person for whom it was purchased as a gift.

How State Law Relates to this Warranty: This warranty gives you specific legal rights, and you may also have other rights which vary from state to state.

To locate your nearest service dealer dial 1-800-345-8746 in the United States or 1-800-668-1238 in Canada.

MTD Southwest Inc

550 N. 54th Street
Chandler, AZ 85226 U.S.A.